

LETECH[®]

MARINE

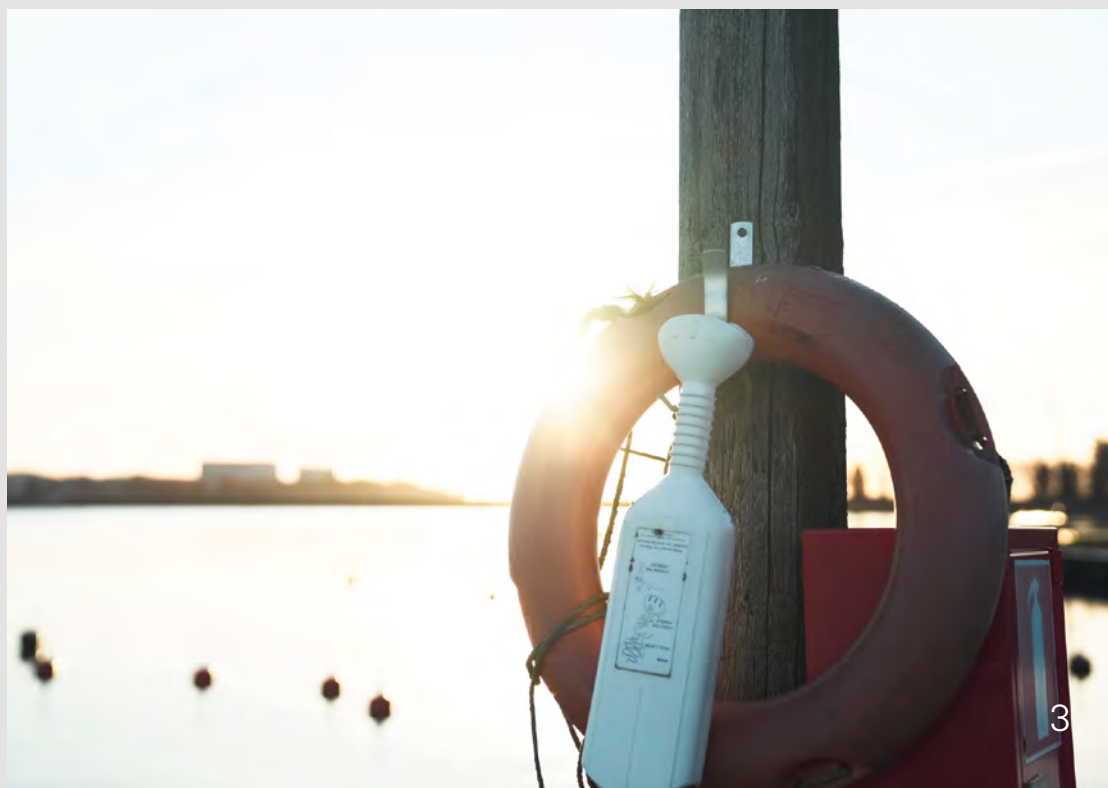





WHO

WE

ARE

ON LAND

As a recognized specialist in off-road vehicles, we provide our customers with the optimal companion for every adventure. Our focus is ensuring that our vehicles and accessories can withstand extreme conditions through thoughtful design, durability, and the highest quality. Guided by these principles, we are moving in a new direction.



AND ON WATER

LETECH Marine combines our expertise and years of experience in design, development, and manufacturing. Our vision is to create innovative watercraft and accessories that unlock new ways to explore and experience the world's coastlines.



MADE IN GERMANY

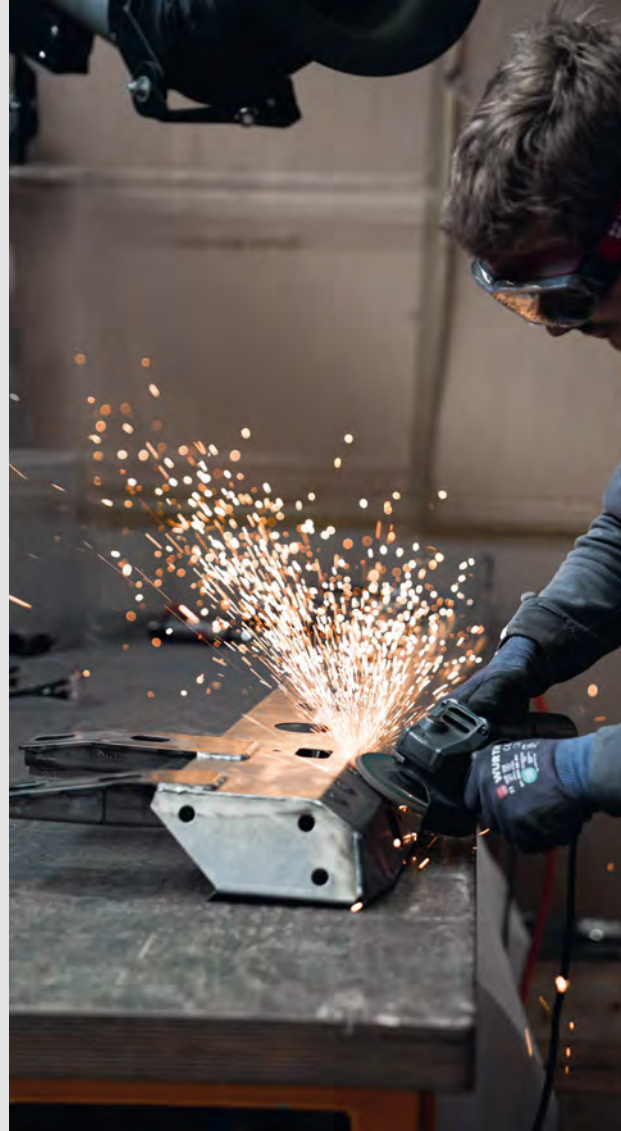

ISO 9001:2015 CERTIFIED



EXPERIENCED SPECIALISTS



HIGH QUALITY ACCESSORIES
FOR THE MERCEDES-BENZ G-CLASS AND THE INEOS GRENADIER



SPECIAL MODELS AND EXPEDITION VEHICLES
INEOS GRENADIER



SPECIAL MODELS AND EXPEDITION VEHICLES
MERCEDES-BENZ G-CLASS

PRODUCTS

HEADLIGHT BRACKET S1

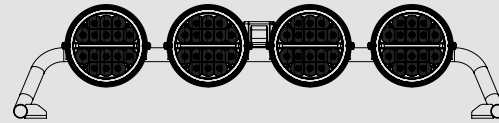

12-13

HEADLIGHT BRACKET SF2

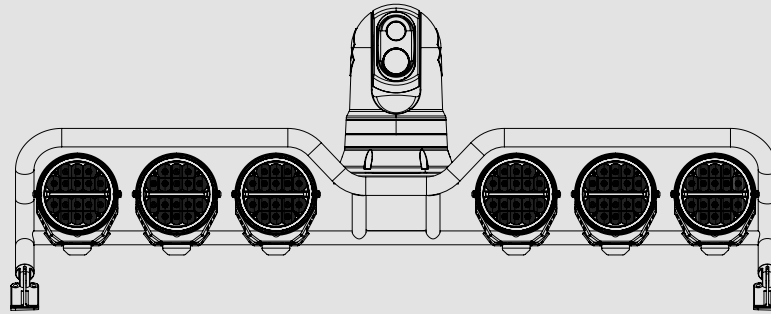

16-19

RADAR MAST R2

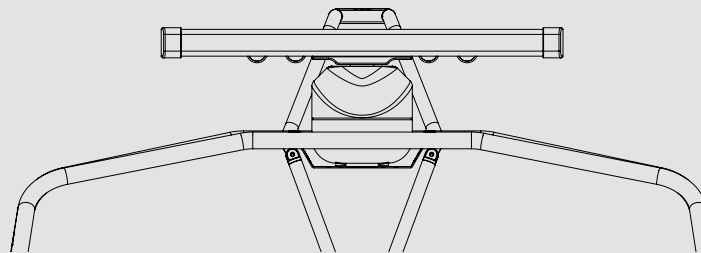

20-23



HEADLIGHT BRACKET S1



Headlight Bracket S1 Four Times the Brightness

To navigate safely through challenging waters even in the dark, additional lighting is essential. The headlight bracket S1 is equipped with 4 LED spotlights, which, with a total of 22840 lumens, provide sufficient brightness to adequately illuminate the waterway. It is available in either an electropolished or powder-coated finish. A PCU for adjusting various lighting modes is also included.

Technical Data

Width (a)	1060 mm
Height (b)	245 mm
Length (c)	413 mm
Luminous flux	22840 lm

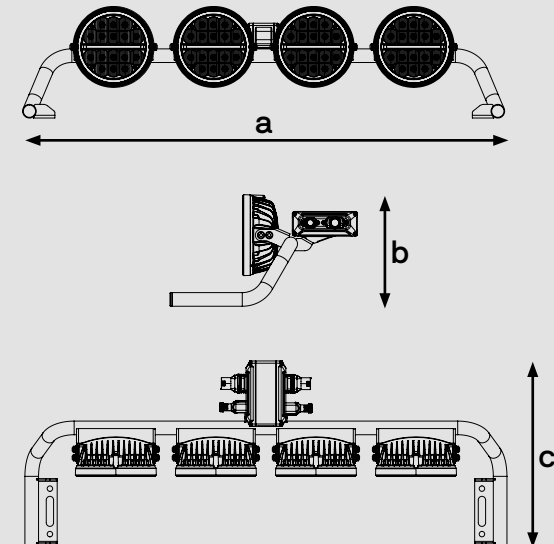

ITEM NO.: 13292	HEADLIGHT BRACKET S1 (POWDER-COATED)	
ITEM NO.: 13291	HEADLIGHT BRACKET S1 (ELECTROPOLISHED)	



With the LETECH PCU (PowerControlUnit) it is possible to switch between three pre-programmed lighting modes. This means that the lighting can be optimally adapted to any situation. With its anodised aluminium housing and laser-engraved LETECH logo, the PCU is not only functional but also visually appealing. The LETECH PCU is already included in the headlight bracket S1.

ITEM NO.:
10361

LETECH PCU

LETECH POWER CONTROL UNIT

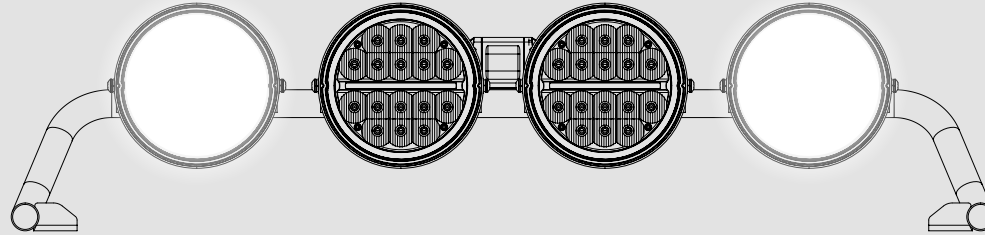
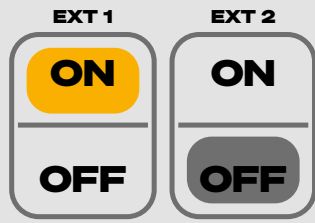

11420 lm

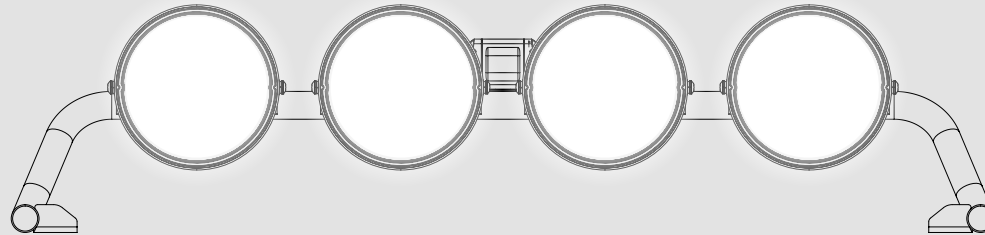

22840 lm

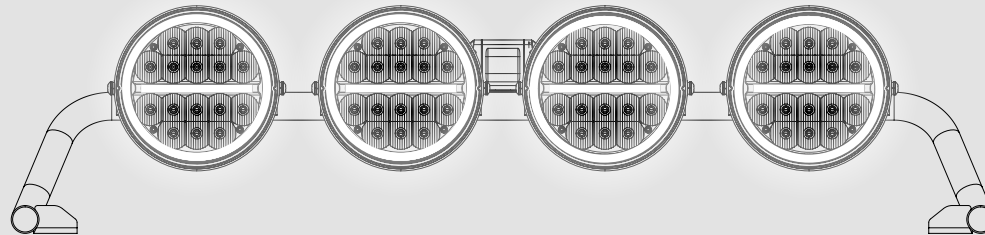

**Position
Light**



HEADLIGHT BRACKET SF2





Headlight Bracket SF2 Six Times the Brightness

The headlight bracket SF2 ensures a secure hold and optimal alignment of the LED spotlights, even in rough seas. It also allows for easy installation of a night vision camera, which blends seamlessly into the design. It is available in either an electropolished or powder-coated finish.

Technical Data

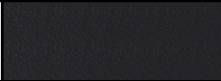
Width (a)	1667 mm
Height (b)	662 mm
Length (c)	398 mm
Luminous flux	34260 lm

ITEM NO.: 13421	HEADLIGHT BRACKET SF2 (POWDER-COATED)	
ITEM NO.: 13420	HEADLIGHT BRACKET SF2 (ELECTROPOLISHED)	

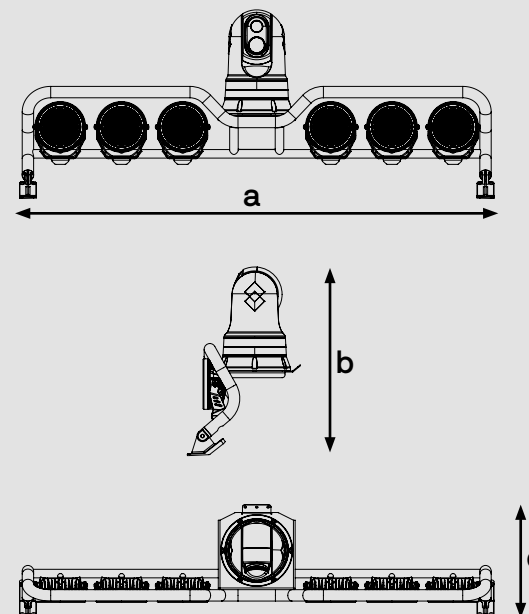







RADAR MAST R2





Radar Mast R2

Secure mount for all components

The LETECH radar mast R2 provides a secure mount for all relevant components, even in very harsh conditions. It stands out for its robust low-profile design, which contributes to the vessel's sporty and professional appearance.

Technical Data

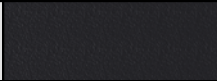
Width (a)	2246 mm
Height (b)	1624 mm
Length (c)	2494 mm

ITEM NO.: 13425	RADAR MAST R2 (POWDER-COATED)	
ITEM NO.: 13426	RADAR MAST R2 (ELECTROPOLISHED)	

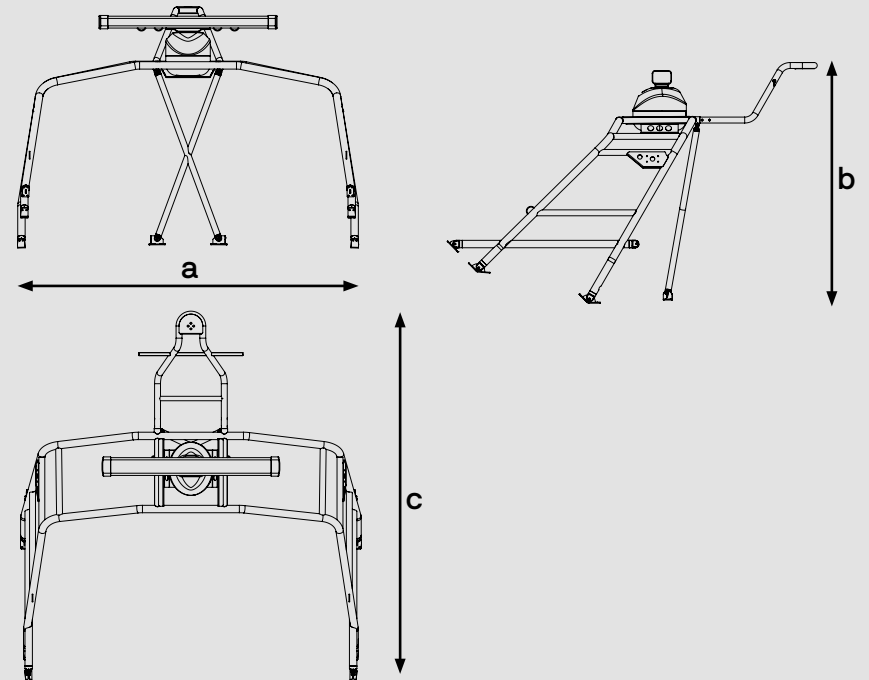





LMT 4.5

LETECH MARINE TENDER





LMT 4.5

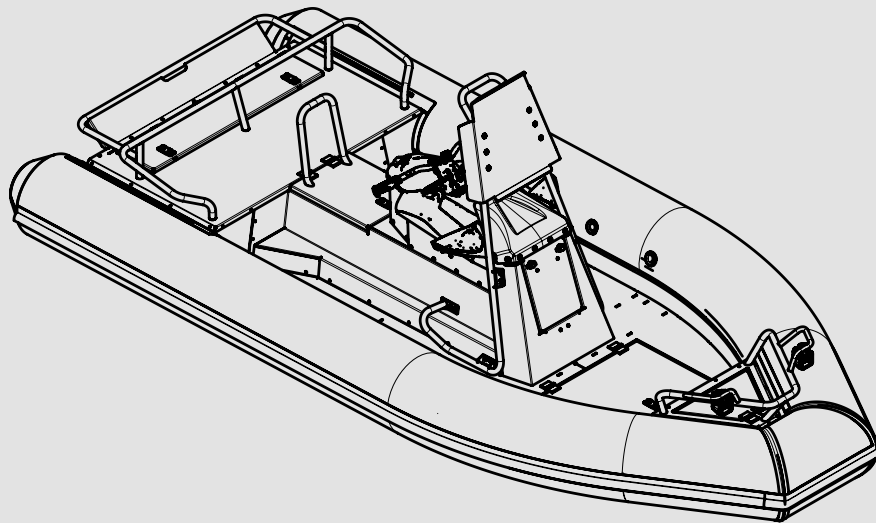

LETECH Marine Tender 4.5

The LMT 4.5 is our first special purpose vehicle designed for use on water. Like our previous special purpose vehicles in the automotive world, this tender embodies uncompromising functionality, maximum durability, and a design engineered for use in demanding environments.

The hull is made of 3 mm thick marine-grade aluminum and impresses with its exceptional strength and corrosion resistance.

Power comes from a high-performance Rotax three-cylinder turbo engine with 300 hp, which delivers impressive performance and high reliability.

The Hypalon tube with three independent air chambers offers maximum safety and stability.

In addition, the LMT 4.5 features well-thought-out design elements such as integrated storage solutions and a multi-functional, coated aluminum bracket for additional lighting.

Every detail of this boat is a testament to precision engineering – 100% Made in Germany, developed and manufactured entirely in our own production facilities.



LMT 4.5

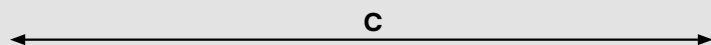
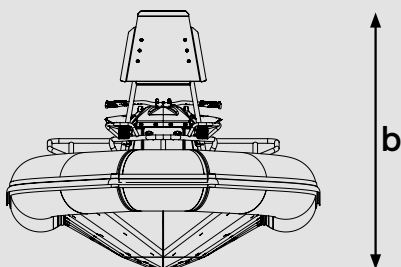
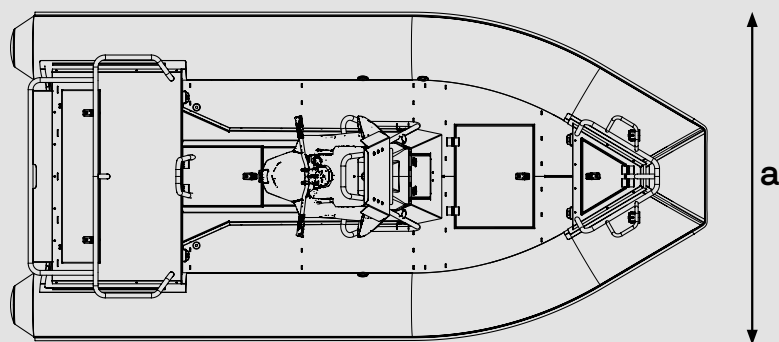

Technical Data

Width (a)	2050 mm
Height (b)	1680 mm
Length overall (LOA) (c)	4500 mm
Hull length	3750 mm
Draught	400 mm
Weight	385 kg
Fuel	70 l
Motorization	ROTAX 1630 ACE - 300
Power	300 HP / 220 kW at 8000 1/min
Power unit	Jet
V max.	50 kn
Cruising speed	22-27 kn
Cruising range	75 NM
CE category	C



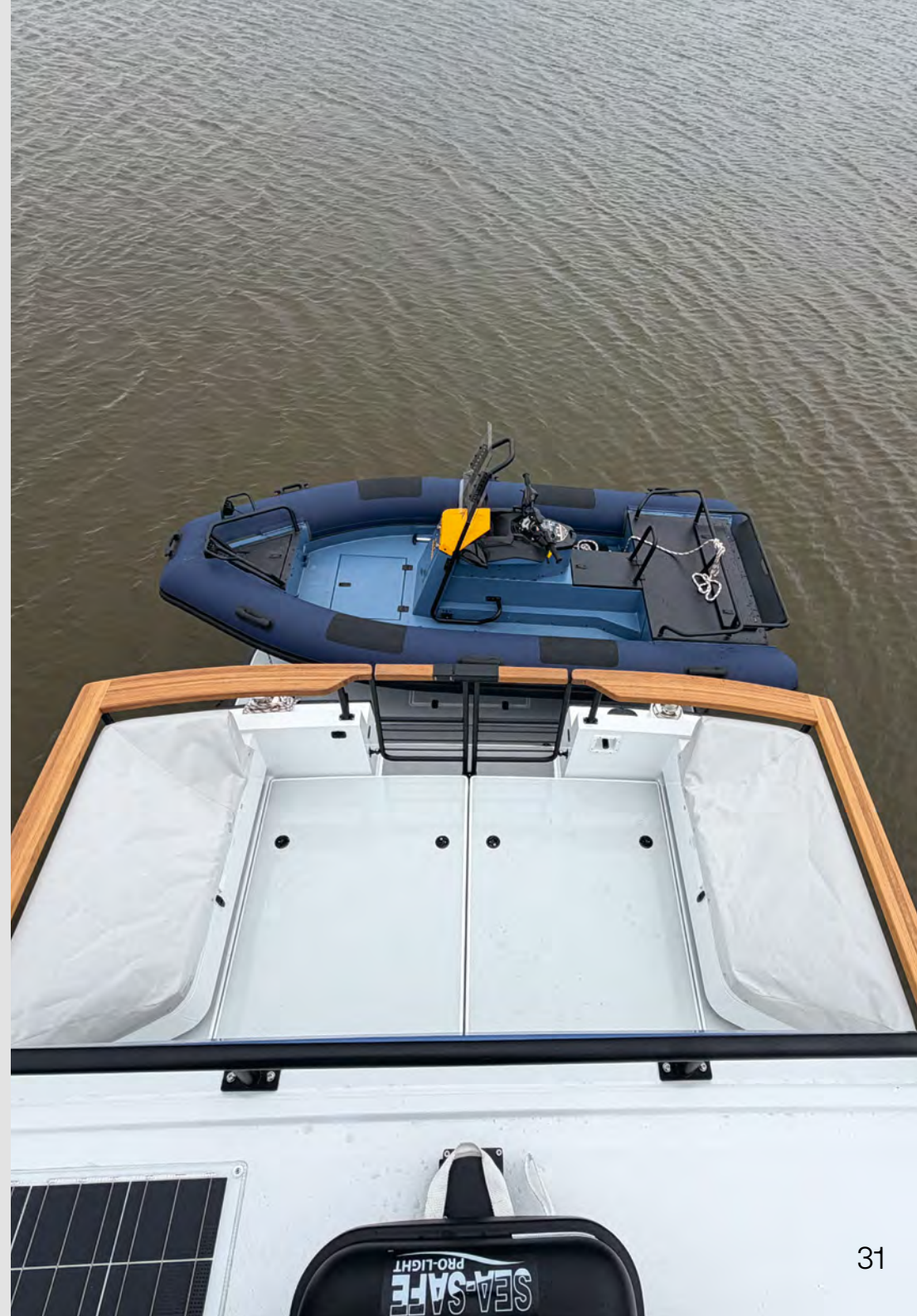

LETECH GmbH & Co. KG
Reizenwiesen 19
73642 Welzheim
Phone: +49 (0) 7182 935650
eMail: sales@lennartz-technik.de

Further information: We reserve the right to make technical and visual changes in the course of product development. Some of the illustrations show accessories that are not included in the scope of delivery of the item described. All products are protected by a utility model. Unauthorised imitation or copying will have legal consequences for the originator.
Last update of the information: 05/2026

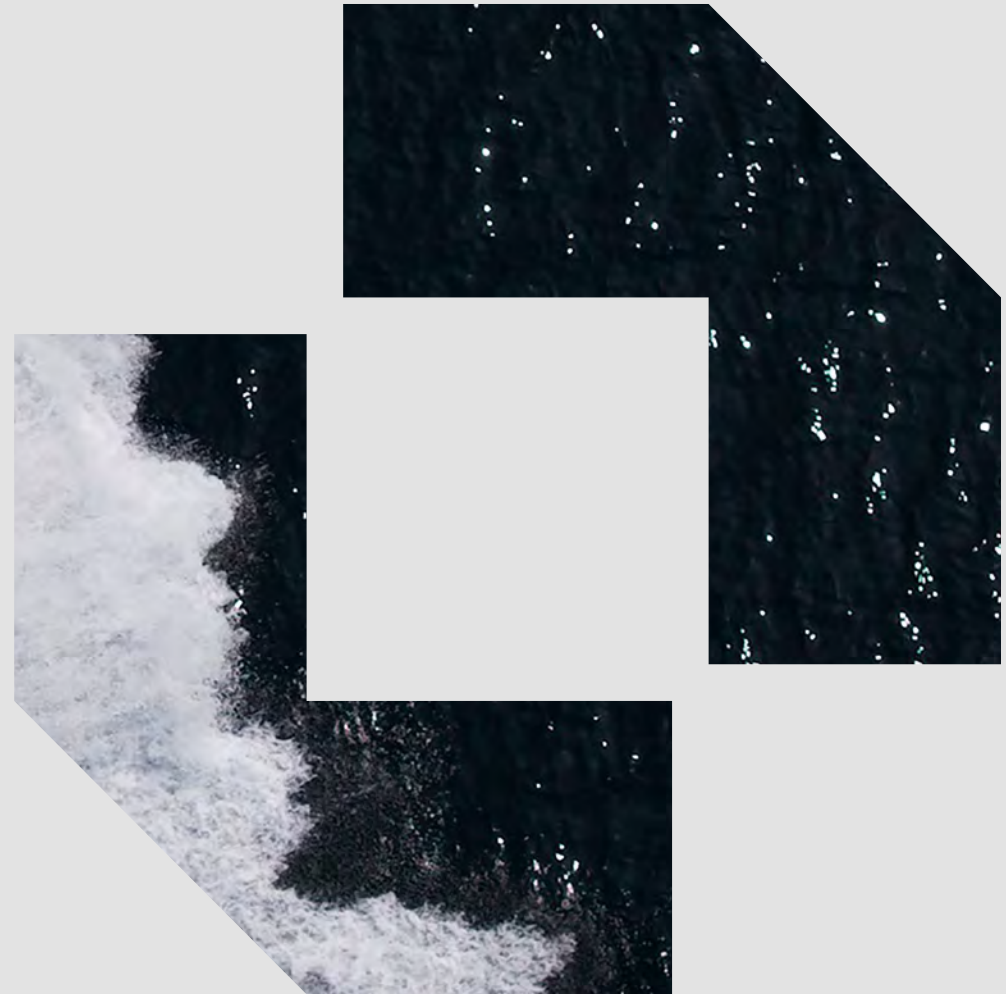

LENNARTZ-TECHNIK.DE